

Order Number = Base Model + 12 Option Codes		
Base Model		M872
Optional Functions	Price Adder	Option Codes
Auxiliary Power		
V10 Universal plus COO	NO	3
V10 Universal plus blank	NO	4
Option Slots 1-5		
C00 Blank Cover	NO	0
Open for P31 in next slot	NO	Y
P20 Modbus Plus	YES	4
P30A 8 DIO Low Range	YES	6
P30A 8 DIO High Range	YES	8
P31 16 DIO Low Range	YES	7
P31 16 DIO High Range	YES	9
P40 8 input 0-1mA	YES	W
P40 8 input 4-20mA	YES	V
P40 8 input 0-10 Vdc	YES	U
Option Slot 6		
COO Blank Cover	NO	0
P30A 8 DIO Low Range	YES	6
P30A 8 DIO High Range	YES	8
P31 16 DIO Low Range	YES	7
P31 16 DIO High Range	YES	9
P10 Ethernet	YES	1
P11 Ethernet	YES	2
P12 Ethernet	YES	3
Host/Memory		
H11 with 1MB	NO	2
H11 with 256MB	YES	4
H11 with 512MB	YES	6
Analog Processor		
A10	NO	1
Option Slot 7		
Open for S1X in next slot	NO	Y
Signal Input		
S13 UL 100A Max	NO	1
S14 UL 20A Max	NO	2
S15 UL 4A 1A Max	NO	3
S13 CE/UL 100A Max	NO	4
S14 CE/UL 20A Max	NO	5
S15 CE/UL 4A Max	NO	6
S16 UL 20A/100A Max	NO	7
S17 UL 4A/20A Max	NO	8
S16 CE/UL 20A/100A Max	NO	9
S17 CE/UL 4A/20A Max	NO	A
Firmware Revision		
Latest Available	NO	X

Build order number by selecting base model (872) and adding one option code from each category. A section for each option slot must be made. An example with 2 P31, P10, and 256Mb is 87249Y900141Y1X. Note that only one P20, P10, P11, or P12 per unit can be selected.



Bitronics® 70 Series

M87x Family

M872 Modular IED

Long Chassis

Dual Line

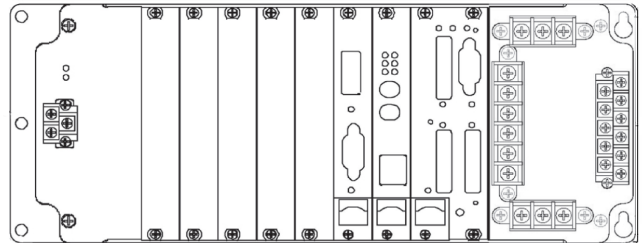

Measurements: Volts, Amps, Power (real, reactive, apparent), Power Factor, K-factor, harmonics (individual, odd, even, TDD, THD), demands, energy, frequency, unbalance, impedance, sequence components and phase angle. Includes many per-phase & total parameters, for over 2000 measurements.

Local Indication: Optional detached display M870D

Serial Ports & Protocols: One RS-232 DB9 and three configurable RS-232/RS-485 ports. Modbus, DNP3, and ZMODEM protocols supported simultaneously.

Current Inputs: Six inputs. Selectable CT ratios. Five signal input ranges available: 5A nominal to 100A max, 1 or 5A nominal to 20A max, 1A nominal to 4A max, 5A nominal to dual range 20A/100A max, or 1A nominal to dual range 4A/20A max.

Voltage Inputs: Eight inputs, measures two buses. Field selectable scaling of PT ratios. Nominal 120V ac up to 600V peak to ground.

Auxiliary Inputs: Two additional voltage inputs suitable for measuring AC or DC. Nominal 125V dc/120V ac up to 600V peak to ground.

Auxiliary Power: Wide-range universal power supply, V10, nominal 24-250V dc/69-240V ac.

Optional Modbus Plus: Modbus Plus protocol supported via optional P20 Modbus Plus module.

Optional Ethernet & Protocols: 10BaseT/100BaseTX RJ45 port (P10), or with added 10Mb (10BaseFL – P11) or 100Mb (100BaseFX – P12) fiber optic port. UCA2, DNP3 TCP/IP, DNP3 UDP, MODBUS TCP/IP, telnet, and FTP protocols supported simultaneously.

Optional Digital I/O: Four options are available for digital inputs and outputs. P30A has a total of eight IO and P31 has a total of 16 IO. On both, four of the inputs can be used as either inputs or outputs. Either can be supplied in low range (100V dc max) or high range (300V dc – default setting) The P31 requires two module slots.

Optional Transducer Input: Three ranges of the eight input P40 transducer input module are available; 0-1mA, 4-20mA, and 0-10V dc.

Mechanical: 13.5" (342mm) W x 5.2" (132mm) H x 8.8" (224mm) D

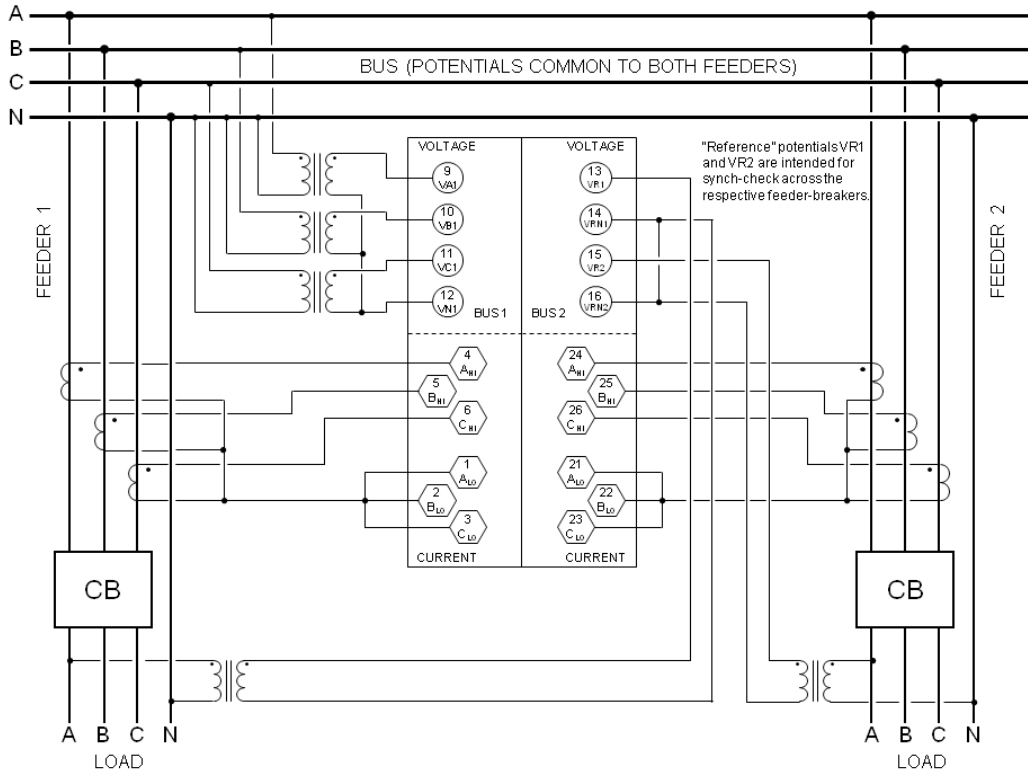

Typical Wiring Diagram - refer to M87x User Manual for other diagrams

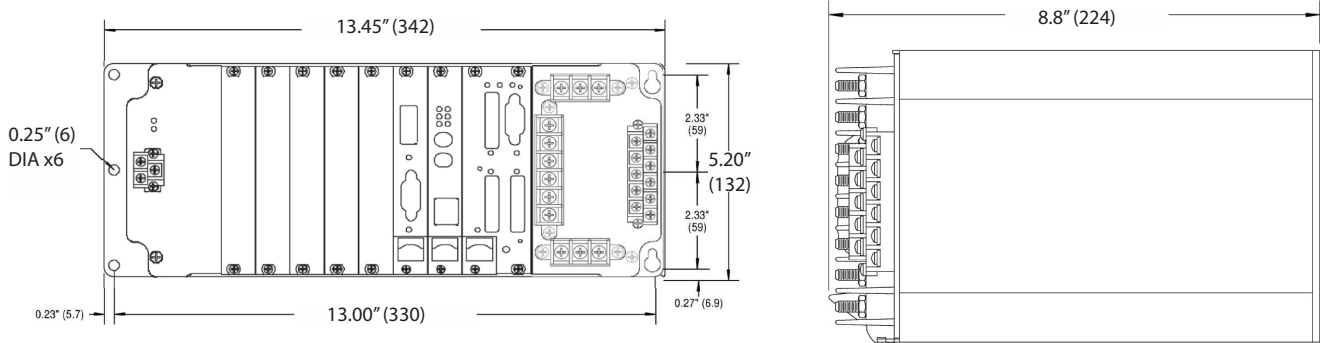

Overall Dimensions - maintain 1.75" (44mm) clearance top and bottom

Contact: