

Putting Your DA To The Test
 Russell Fanning, We Energies and
 Eric Schultz & Patrick Russo, NovaTech, LLC

ABSTRACT

Distribution Automation systems, and particularly feeder automation schemes, look great on paper, but how much do you trust them in the field at the moment you place them in service for the first time? At We Energies we have developed a new and totally unique method of developing DA systems. Our DA system was developed as one of the cornerstones of the Distribution Vision 2010 advanced automation technologies. This system integrates relay controlled substation feeder breakers, automated line reclosers and automated switches on numerous feeders with multiple bridging points into a single control at the substation. We were able to develop automation control software that runs on multiple platforms to test the DA system in three different testing environments to save time and resources in debugging DA applications. First the DA scheme was developed, bench tested and proven out on a PC. In that setting DA Simulation tools allow us to emulate fault conditions through the software and observe the execution of the simulated automated feeder automation in real-time. The same software code is installed in the substation DA control equipment to operate automated breakers and line devices using real telecommunication systems in a controlled simulation environment. Final testing is proven when actual fault conditions are injected into the field IEDs through test equipment and the system is allowed to operate live in an unmodified field installed setting. This paper will discuss the technology of the DA system design, the simulated automation system tools, and the testing procedures that were used to place several independent and unique DA schemes in service at We Energies in 2004.

ADVANCED FEEDER AUTOMATION PROJECT – GLENDALE SUBSTATION CONVERSION

Distribution automation systems have been used at We Energies for many years; however, most of what was referred to as DA were little more than dedicated automatic transfer schemes. Over the last decade, automation schemes have matured as the microprocessor-based intelligent electronic devices have become prevalent in substations and on remote line equipment. Substation integration of protection IEDs had a great impact on our industry to reduce construction cost and add new operational functionality. However, first implementations were limited to how far you could hardwire serial communications between devices. Therefore, early automation was limited to enhancing SCADA, local control and logical switching operations confined to devices inside the substation fence.

As the controls for field installed IEDs have evolved, so have the telecommunications systems that connect those devices to the EMS system. It is common practice to include some

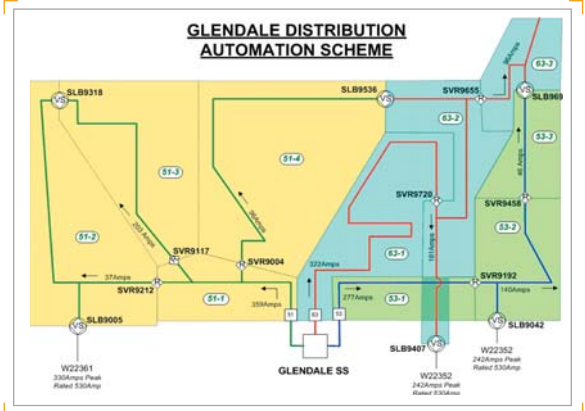

Figure 1: Advanced Feeder Automation Project Schematic

telecommunication equipment at key feeder sectionalizing devices. Many utilities have automated these devices through direct remote access and control to their EMS system, but the human element remains an integral part of the DA system. Other utilities have chosen to pursue feeder automation schemes using proprietary automation schemes to provide automatic sectionalizing, fault isolation and automated bridging schemes based on vendor specific hardware and telecommunications systems. However, off the shelf solutions should not be assumed to be a universal plug and play solution that works in all cases. The truth is that there is NO perfect solution that meets all the needs of every utility.

Most utilities, We Energies included, prefer options, such as options that allow the utility to leverage the resources that they already have, options that allow multiple vendors' equipment to be implemented into one integrated system, or options that maintain control of the DA system for the system operators while assuring the field crews continue to work in a safe and secure environment.

In 2001, a high profile area in a northern suburb of Milwaukee, Wisconsin was being converted from an older 4kV distribution system to a more efficient 13kV. To obtain local approvals, We Energies assured local officials that the customers would not see a difference in service reliability between their old system and the new 13kV system, even though the new 13kV feeder configuration had three times more mainline exposure as the older 4kV feeders serving the same customers. A feeder automation scheme was required to achieve this level of reliability.

This required that any outage would be confined to a small area of faulted 13kV feeder no bigger than the original coverage of the 4kV feeder. Unfaulted portions of the 13kV

Contact:
 NovaTech, LLC
 15541 W 110th ST
 Lenexa, KS 66219
 T: 913.451.1880
 F: 913.451.2845
www.novatechweb.com

feeder may be minimally subjected to momentary outages. Unfaulted sections of feeders downstream of the fault should be restored to service in less than 5 minutes so that associated outages would not be included in the calculations for sustained outage statistical indices such as SAIDI and SAIFI.

We Energies had already developed the POD concept [1] earlier in 2001. A POD, or Premium Operating District, is the term given to that portion of a feeder that can be isolated and/or switched to an alternate source through feeder automation. The POD methodology for feeder automation simplifies the process in designing and implementing DA projects and greatly improves reliability to customers served by such systems. The rudimentary concept of the POD method states that “a customer served within a POD will have the perceived reliability as if the feeder serving the customer is no larger than the POD itself”. This is true since the customer within the POD will never be subjected to a sustained outage for any 1st contingency condition outside of his own POD.

The Glendale area to be converted was analyzed and a plan was designed, using the POD method, to sectionalize the converted 4kV feeders into 10 PODs on 3 different 13kV feeders, Figure 1. This was accomplished with the installation of 7 Cooper Form 5/NOVA reclosers at the midline sectionalizing points and 6 S&C ScadaMate switches at the normally open automated bridging points. We also needed to integrate the breakers at the head of all three feeders into the overall feeder automation scheme.

At first glance, this does not seem like a difficult chore to build, and we proceeded to search the available technologies that could get us close to our objectives. When We Energies researched who was implementing the next level of feeder automation. We did not find any system available on the market at that time that could accommodate the complex feeder bridging configuration in the area, nor could we find a system that could integrate the substation feeder breaker into the feeder automation scheme. The next step was to find a vendor that could work with us to develop this system. We Energies finally selected NovaTech LLC, in Lenexa, KS to develop this product.

DISTRIBUTION AUTOMATION CONTROLLER DEVELOPMENT

We Energies laid out the functional and sequential logic specifications for the new DA Controller. NovaTech then developed the new DA Logic processing module and implemented it on the same hardware platform as their existing products. The new product was labeled as the DA-Master.

NovaTech's DA-Master was developed to be an advanced Distribution Automation controller that utilizes existing protective devices, resulting in a low cost, powerful Master controller. The DA-Master can operate in both single-feeder and multi-feeder configurations, and even multi-substation schemes. Third party Intelligent Electronic Devices (IEDs) provide system information over most commonly used communication media. When fault data is detected, trip-close commands are issued to isolate and correct abnormal system

conditions. The DA-Master can also share information with SCADA Masters, RTUs, IEDs, and other devices using a multitude of protocols.

DA-Master hardware is based on NovaTech's Orion family of communication processors, resulting in a substation

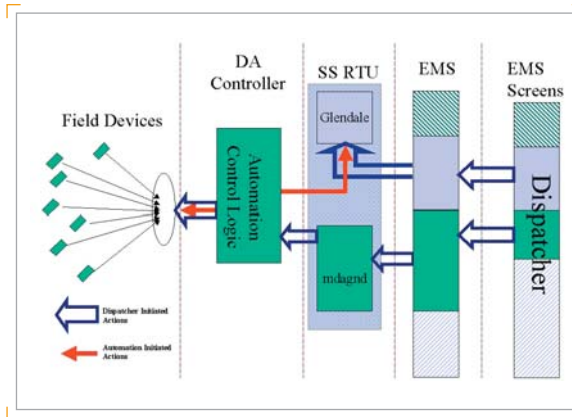

Figure 2: Automation Control Paths

hardened controlling device. The DA-Master interfaces with Intelligent Electronic Devices (IEDs) using their legacy or industry standard protocols. The DA-Master can be expanded to support up to 17 serial ports, supporting integrated RS232, RS485, fiber optics, dial-up modem, Ethernet TCP/IP, and discrete inputs and outputs. Most importantly, the DA-Master contains no fans, no hard drives, and no moving parts.

Configuration of the DA-Master is easily accomplished using NovaTech Communications Director (NCD) software, providing a simple drag and drop interface. NCD drastically reduces configuration time by pre-packaging IED protocol information, allowing the user to focus on the project, instead of learning about protocols and IEDs. Offline configuration allows the user to configure the system without connecting to the IEDs, enabling configuration outside of the substation. Separate polling groups can be configured to adjust update times on a per point basis. Unsolicited responses from IEDs are also accepted.

The flexibility of the DA-Master allowed us to easily add the feeder automation into the existing infrastructure of the existing integrated substation design. This installation utilized three ports on the DA-Master. One port at the DA-Master was connected to a master radio that was used to communicate to 6 S&C ScadaMate switches and 7 Cooper Form 5/NOVA-DC reclosers installed on a system of 3 13kV feeders out of the substation. The existing TASNET RTU at the substation was upgraded with 2 new Network Interface Modules, NIMs, which were then interfaced to the NovaTech DA-Master to 2 dedicated RS232 ports. A standard feature on the DA-Master includes a dedicated port for local programming using a PC running the NovaTech Communication Director software.

Contact:

NovaTech, LLC
15541 W 110th ST
Lenexa, KS 66219

T: 913.451.1880
F: 913.451.2845
www.novatechweb.com

The first port at the DA-Master was connected to the master radio using an RS232 interface and was configured as a MASTER port to the field devices. It was used to poll the field devices to gather information for the DA logic scheme every 30 seconds (on average). This port was also used to send control commands to the field devices to operate whenever the DA Logic processing scheme commanded to do so. For this installation, a licensed radio frequency Multiple Address System was used.

The second port at the DA-Master was configured as a SLAVE port to the substation RTU, Figure 2. This allowed the EMS system to pass monitor and control commands to the field devices through the substation RTU to the DA-Master. This maintains remote access and control of all automated field devices through the EMS system continuously and in parallel with the processing of the DA logic processor. System operators could operate field devices at their discretion without creating a conflict or contradiction in the DA logic.

The third port of the DA-Master was configured as a MASTER port that was used to poll the TASNET RTU, through the NIM, for key information about substation equipment. This additional MASTER port sits in parallel with the EMS master thus allowing the DA-Master to control designated breakers, as needed, to integrate them into the overall feeder automation scheme without competing with the EMS system.

DISTRIBUTION AUTOMATION SIMULATOR

One of the requirements that We Energies included in the development of this product was the development of a simulation tool that would allow the system to be tested and proven out in a bench testing environment. This dictated the approach to be used in developing the Distribution Automation logic. The source code of the DA logic processor had to be compatible to run in both the Orion native operating system and the PCs Windows base operating system.

The internal data structure of the Orion platform, as established by the NCD software, was ported into an equivalent Microsoft ACCESS database. Data in each database is referenced by field names common in both systems which allowed the exact same source code, using the same data structures and logic processing to be implemented on both platforms. The only technical difference between the systems was the source code compilation process.

Before commissioning the new DA system we would eventually test the scheme by actually operating the installed field devices through the radio communications system. However, other means were utilized to develop, test and debug the DA logic module BEFORE it would be implemented. This required that systems needed to be developed to provide visual feedback and detailed logging during the execution of the DA Logic processing to confirm proper compliance to the intended operation of the DA scheme.

NovaTech provided the required visual feedback by developing a DA Simulator using its NovaView Plus GUI software.

Their Graphical User Interface (GUI) uses graphics that are created using Visual Basic tools and tied to the elements in the Access database, Figure 3. NovaTech-developed state of the art onboard diagnostics allow viewing of port communications, data values, and communication statistics. These tools provide a clear definition of device and point status.

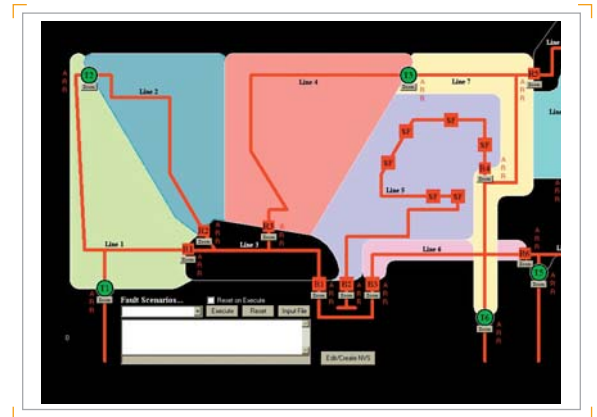

Figure 3: Glendale Project DA Simulator GUI

The DA Simulator package models the entire distribution system, including simulation of fault conditions at each IED and verification of automation schemes before equipment is installed in the field. DA Simulator combines the functionality of the DA-Master software with NovaView Plus GUI software. The DA Simulator becomes an interactive graphical representation of all of the devices and control elements incorporated into the DA scheme. The graphical interface includes capabilities of setting pre-fault system conditions including placing devices into abnormal operating states before executing a test to prove that safe operating conditions are maintained throughout the processing of a DA event.

Several test cases were set up in a simple data file that is read by the DA Simulator during the first level of developmental testing, Figure 4. These test files define appropriate changes to states of discrete data elements at IEDs at defined time intervals to represent the real-time feedback that would be received by the DA-Master during a system outage. These test cases are set up to include changes in switch status, fault indication, operations counters and loss of voltage detection.

As an example, a simple case could be set up to reflect a cable fault in the first POD outside of the substation breaker. The full feeder may contain a total of 2 PODs with one mid-line automated recloser and an automated bridging switch at the end of the feeder. This test case would be set up to reflect a fault indication and open status at the breaker at the time of the fault. No fault indication would be indicated at the recloser. Loss of voltage would be reflected at both the recloser and at the switch location. The test case would reflect a change of state of the breaker and a retrip of the breaker at its first and second reclose interval. The relay lock-out condition would then be reflected in the test case.

Contact:

NovaTech, LLC
15541 W 110th ST
Lenexa, KS 66219

T: 913.451.1880
F: 913.451.2845
www.novatechweb.com

Processing this case using the DA Simulator would visually indicate the change of state of the breaker during the reclose cycle until it reaches lockout. The graphic representations of the downstream conductors also change to indicate whether the conductor is in an energized or de-energized state throughout the simulation. When the relay's lockout indication is set, the DA logic processor begins to step through the sequenced DA scheme by opening the midline DA recloser, followed by closing the DA switch.

Visual observation of the graphics representation in the GUI alone is not sufficient to confirm that proper sequencing of the automated switching steps took place. Log files created during the test are time stamped to the millisecond to clearly indicate that confirmation the complete execution of one operational switching operation was obtained before issuing the command to initiate the next action, Figure 5.

The DA Simulator can also be used to test cases when the system is not fully reset to its normal state prior to a test. The DA-Master maintains three operational status bits on each automated device; 1) Auto/Manual, 2) Local/Remote and 3) Normal/Abnormal operating position i.e., open/closed. A device is considered in its "fully automated" state if and only if it is in Auto and Remote and Normal operating positions.

Whenever a device is not in its fully automated state the automation at the device is restricted. In addition, the devices on either side of the restricted device, i.e. all devices that define the PODs to either side of the restricted device, are also "limited". A device that is operating in a "limited" mode is not allowed to be closed via the automation system, although they can be opened to provide sectionalizing.

In the previous example, if the recloser were placed in Manual (not Auto) mode, then it would not be opened to sectionalize the fault. The restriction at the recloser would disallow the execution of the "open" command. This in turn would block the close of the automated switch step the required previous step would not be completed. However, if the recloser was still in its fully automated mode, but the DA switch was placed in Manual, then the recloser would be allowed to open, but the switch would not be allowed to close.

Placing a device in either Manual or Local will accomplish the same effect to the operation of the DA scheme. The slight difference is that a device that is placed in Manual while also kept in Remote can still be remotely operated by remote operation through the EMS or substation HMI system. However, a device placed in Local, whether the placed in Auto or Manual, can only be operated by the field operator at the local control of the device.

SIMULATED FIELD TESTS

The DA Simulator tests involved only software running on a PC and no actual field equipment was connected to execute these tests. When the DA Simulator tests sufficiently proved out the intention and sequencing of the DA scheme the next stage of testing moved out to the substation.

The DA logic scheme was defined in the DALogic module of the NovaTech Communication Director configuration software and loaded into the DA-Master. New simulation test cases needed to be created, but only the format of the files was changed, Figure 6. The DA Simulator test cases are simple space delimited files that are read by the NovaView Plus GUI program. The new test cases are an executable .BAT batch files that are downloaded to the DA-Master and invoked through the programming port using a PC. The format is slightly different, but the same time delays and change of state conditions are defined in these batch files.

Zone 53-1 Head end Fault		
Time	Tagname	Value
0	FMD_ZT_LB@(B3)	0
0	FMD_52AT@(B3)	1
0	FMD_79LO@(B3)	0
1000	FMD_ZT_LB@(B3)	1
1000	FMD_52AT@(B3)	0
1000	B Phase voltage present @(R4)	0
1000	B Phase voltage present @(R7)	0
1000	F2 Phase B V rms @SLB9407 (T4)	0
1000	F1 Phase B V rms @(T6)	0
3500	FMD_52AT@(B3)	1
3600	FMD_52AT@(B3)	0
10000	FMD_52AT@(B3)	1
10100	FMD_52AT@(B3)	0
10100	FMD_79LO@(B3)	1

Figure 4: Sample Simulator Test Case

During this level of testing, no fault current is actually injected into any IED to force a trip event. The batch files are used to "stuff" values into the DA-Master registers for key data values. However, the DA-Master is polling devices through actual telecommunication schemes during these tests, and when devices are polled, the returned data reflects the actual state of the device in the field, including the fact that no fault indication is present. Therefore, it is important that forced values are maintained throughout the duration of the test. NovaTech implemented a feature in the DA-Master that allows the forced value to override the polled data for a designated time, as defined in the batch file. For example, if a test required we simulate that a midline recloser tripped to lockout, then the "no lockout" condition is overridden by the held value from the batch file. Stuffed values are typically held for three minutes which is long enough to complete the test scenario. The value reverts back to the actual value upon the first integrity poll to the device after the timer expires.

Contact:

NovaTech, LLC
15541 W 110th ST
Lenexa, KS 66219

T: 913.451.1880
F: 913.451.2845
www.novatechweb.com

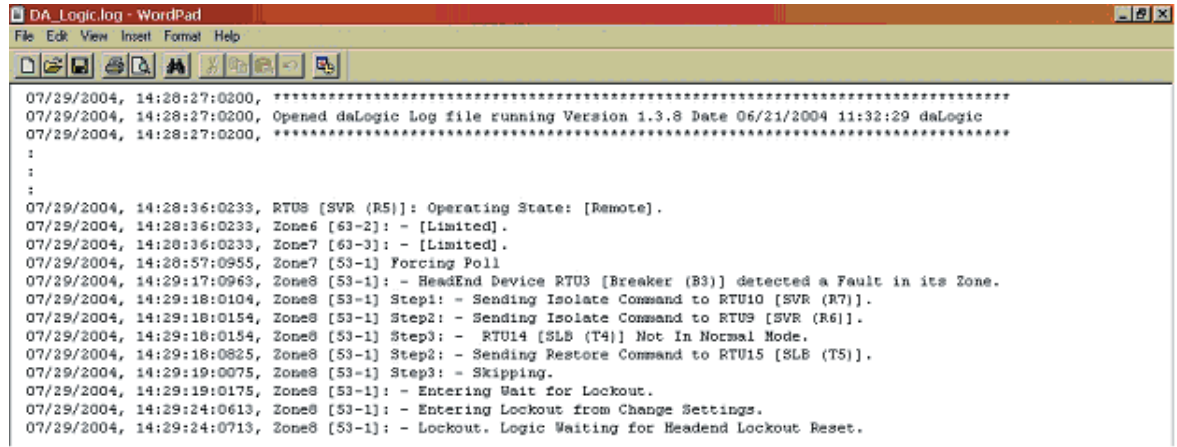

Figure 5: Sample Log File

The testing at this stage issues actual trip and close commands to field devices to provide real-time feedback into the scheme for confirmation of switching operations before subsequent switching operations are issued. Two methods have been used to accomplish this without creating disruptions on the distribution system. Devices are either bypassed and/or disabled. In some cases, normally closed reclosers are bypassed when bypass switches are installed, but this requires the resources of a qualified switch operator to perform the task. The preferred method that we have utilized was to decouple the control from the recloser and install a test box. The recloser test box is a passive device that emulates the status of the recloser during our field tests. This box can be installed in the field in just a couple of minutes without the assistance of a switch operator. Similar boxes were installed at our ScadaMate switches. With these test boxes installed or devices otherwise suitably disabled, we were able to perform any tests necessary including setting up system configurations that would otherwise not be allowed.

The field simulation tests proved to be very successful. However, some conditions found that did not reveal themselves in the DA Simulation tests.

In this project, all of our field devices communicate using a MAS radio using DNP 3.0 protocol. The ScadaMate switches that were being used in our scheme had been installed using a single-phase potential transformer for loss of voltage detection that also provided power to the battery charger. Our previous experience had shown that the 5-watt radios used for this application would quickly drain the battery if we polled the devices faster than once per minute. Our requirements established that full DA isolation and remedial switching needed to be completed within 5 minutes, but our objectives were to complete this task in less than one minute, which was not possible if we were polling field devices only once per minute.

Our initial intention was to implement Unsolicited Report By Exception capabilities of the DNP 3.0 at the field devices so that we could poll devices infrequently to conserve battery and allow long period of no communication traffic to reduce

data collisions. No matter what we tried, we were unsuccessful. Within 2 days of starting up some of the IEDs would stop responding to polls. We chose to move to a sequenced polling of the field devices once per minute, instead of spending time debugging a communication scheme that might not work.

When the field simulation tests proved to be too slow, NovaTech provided a solution. First, the reclosers and the ScadaMate switches were put into different polling groups. Since all of the switches were installed at normally open bridging points, they are not used to detect faults to initiate a DA process in this scheme, and they continued to be polled once per minute. The reclosers were more critical to the DA process and their polling group was increased to once every 30 seconds. Secondly, NovaTech implemented a ForceGroup feature in the DA Logic. This implied that when the first device of any polled group responds with any condition that might trigger a DA response, the DA-Master would suspend its current polling sequence and force an integrity poll at each device at that time. This assured a response from all field devices within 45 seconds of the fault and completed the execution of any DA sequence within an average of 2 minutes.

These tests also revealed that some faults were not completed to the full extent possible when some devices were not initially in a “fully automated” mode. As the tests proved out more complicated scenarios, two and three independent switching sequences needed to be executed. When a device in an earlier sequence was prevented from completing due to a limited field device, subsequent switching sequences were also prevented from completing. We worked with NovaTech to develop new features into the DA Logic processor that would allow multiple switching sequences to be programmed into the configuration without interference from other device restrictions.

Contact:
 NovaTech, LLC
 15541 W 110th ST
 Lenexa, KS 66219
 T: 913.451.1880
 F: 913.451.2845
www.novatechweb.com

FINAL IMPLEMENTATION: FAULT INJECTION TESTS

As we moved to the full implementation, testing and commissioning of the system, most of the problems had already revealed themselves and been resolved. Since full implementation involves many more resources including field switching personnel, relay testers and testing equipment, SCADA technicians and start-up engineers, any problems that need to be resolved in the last stages would be costly. DA Simulation testing was used to develop and prove out the overall feeder automation scheme in an office setting. Simulated field tests allowed us to prove the feeder automation scheme with real-time feedback into the system. Each stage of testing proved valuable in revealing unforeseen problems that were resolved at a point when the cost and effort to correct the problems were relatively low.

Earlier testing proved all aspects of the feeder automation scheme except for the interaction of the IED processing of a real fault with the DA-Master. The only way to prove that the DA-Master detected and processed fault contingency scenarios properly was to actually allow the protective IEDs to generate the real messages that would trigger the DA process.

Simulated field testing “stuffed” data into the DA-Master to trigger processing of an event. Real communications were used to provide proper feedback to the DA-Master, but simulated faults do not substitute for the real thing. Field reclosers and ScadaMate switches were bypassed or decoupled from their controls in the same way that was used for Field Simulation testing.

No data simulation of any kind was used in the final fault injection testing. Field switching devices were decoupled from their controls and/or by-passed as in the field simulation tests. A PC was connected to the programming port of the DA-Master during testing only to observe the communication traffic and to examine log files generated for a fault condition.

Fault injection testing was performed at several points on the Glendale DA system. The Cooper ME tester was used to inject fault current at midline reclosers to generate fault targets in the reclosers. Doble test equipment was used at the SEL-251 relays to inject fault current to simulate head end faults on the feeders.

Fault injection testing at the Cooper Form 5 reclosers worked exactly as anticipated. The fault target was received by the DA-Master on the next event poll of the device within 30 seconds of the fault. The DA-Master immediately forced an integrity poll to all field devices. The DA-Master received updated breaker and relay information from the substation RTU every 2 seconds. Within 60 seconds of the fault the location of the fault was properly identified and the DA-Master initiated the sequence of feeder sectionalizing and restoration steps to complete the field changeover in less than 2 minutes.

```
sleep 1000
setvalow "W22353 FMD_ZT @Tasnet RTU" 1 1 1
setvalow "W22353 CBStatus @Tasnet RTU" 0 1 1
setvalow "B Phase voltage present @SVR9192 (R4)" 0 1 1
setvalow "B Phase voltage present @SVR9458 (R7)" 0 1 1
setvalow "F2 Phase B V rms @SLB9697 (T4)" 0 1 1
setvalow "F1 Phase B V rms @SLB9042 (T6)" 0 1 1
sleep 2500
setvalow "W22353 CBStatus @Tasnet RTU" 1 1 1
sleep 100
setvalow "W22353 CBStatus @Tasnet RTU" 0 1 1
sleep 240
setvalow "W22353 FMD_ZT @Tasnet RTU" 0 1 1
sleep 10000
setvalow "W22353 CBStatus @Tasnet RTU" 1 1 1
sleep 100
setvalow "W22353 CBStatus @Tasnet RTU" 0 1 3
setvalow "W22353 FMD_ZT @Tasnet RTU" 1 1 1
setvalow "W22353 FMD_79LO @Tasnet RTU" 1 1 3
sleep 5000
setvalow "W22353 FMD_ZT @Tasnet RTU" 0 1 1
```

Figure 6: Sample Field Simulation Test Case

The only problem that occurred during the recloser fault injection testing was an occasional missed communication between the DA-Master and the field device, which required a resend of the proper command. If the case arose that an automated operation failed to complete after all retry attempts, the processing of the DA event would stop at that point and an alarm would be sent to the system operator through the EMS system. The DA-Master had been configured to retry a control command up to 5 times and our observations showed that we have never had a case when a retry did not successfully complete the operation.

One problem, however, revealed itself during the fault injection tests that were not detected during the DA Simulator tests on the PC nor the field simulation tests. The three port connection to the DA-Master installation previously described in this paper was not the first configuration that was tried. This DA Scheme integrates 3 substation breakers into the feeder automation scheme. Each of the three breakers is controlled by SEL-251 relays. In our first design, the three SEL-251 relays were each connected to a dedicated port on the DA-Master communicating with an ASCII protocol, so the original scheme used 6 ports. During an actual fault injection test, the relay responded to the fault condition as its primary function, as it should. But the SEL-251 suspended communications on its rear port, which was connected to the DA-

Contact:

NovaTech, LLC
15541 W 110th ST
Lenexa, KS 66219

T: 913.451.1880
F: 913.451.2845
www.novatechweb.com

Master. The loss of communications at this port occasionally resulted in a failure to deliver data to the DA-Master causing improper detection of a fault on the system.

We recognized the source of the problem within the first hour of its initial observation. A change to the design was implemented relatively quickly. The revised scheme required some reprogramming of the internal logic of the SEL relays to set an internal bit in the relay that was continuously monitored by the substation RTU. The critical fault information from the relay was then provided to the DA-Master through the 2-second polling of the RTU via the MASTER port of the DA-Master. This resolution eliminated the need for 3 communication ports and 3 RS232 cables to the DA-Master. In addition, this greatly enhanced the performance of the DA-Master because the fault detection bit in the relay is often picked up even when a fault is interrupted by a downstream recloser. Therefore, the 2 second poll to the substation RTU may identify a fault condition on the system before the fault target information is received by the DA-Master during an event poll of the field devices. Another benefit from this change was the initiating of a forced poll of field devices within 5 seconds of the initial fault instead of the 30 seconds that might elapse if a forced poll was only initiated from a field device.

Successful implementation and testing of any DA system does not guarantee successful application of the technology. The process to develop the DA-Master did not start with NovaTech. We had to be sure that the control developed was, in fact, the control that the system operators would trust and use.

We brought key stakeholders from dispatch, field operations, planning, protection, distribution automation, telecommunications and engineering management together early and often. Together we worked through the concepts that would be applied in the controller. We developed the operational safeguards that had to be incorporated into the control, and we developed the Graphic User Interface designs for the EMS screens and the HMI to useful and represent meaningful information.

Final testing was monitored by a distribution control supervisor through the EMS to observe and verify the data that would be conveyed during a real DA event. Training sessions were developed for several user levels including dispatchers and troubleshooters to expose them to the new technology in advance of an automated system event.

FUTURE PROJECTS AND ENHANCEMENTS

We Energies installed its second DA-Master at a single transformer 24.9kV distribution substation in Somers, WI. This substation is fed from a radial transmission line and the area is subjected to a widespread outage for either a transmission line, transformer or bus section failure at the substation. A DA-Master was installed to improve the customer service reliability. The DA-Master will provide automated remote bridging to adjacent feeders through the DA logic based upon

a loss of bus voltage condition at the substation. Feeder sectionalizing and restoration processing at Somers is also being implemented through the DA-Master to further increase reliability.

We Energies will be installing several more automation schemes based upon the DA-Master in 2005. One system will integrate breakers at three different substations with approximately 12 automated field devices using a single DA-Master located at one substation. Other projects will provide load relief at fully loaded distribution substations during first contingency scenarios under heavy loading conditions. Implementing a DA solution at these substations allowed us to defer more costly system upgrades by several years, or possibly indefinitely.

The most ambitious implementation of the DA-Master is the expansion of the use of the device in the Primary Voltage Network System [2] being implemented by We Energies as a pilot project for the Distribution Vision 2010 consortium initiatives in 2005.

SUMMARY

We Energies worked with NovaTech to develop a new Distribution Automation Controller called a DA-Master. The DA-Master includes advanced distribution automation logic to integrate IEDs from multiple vendors using a wide range of communication protocols. The hardware is easily configurable and can be used to implement automation schemes on a single feeder, multiple feeder and multiple substation systems. The Glendale DA system is representative of the feeder automation schemes that can be controlled.

Testing of the advanced feeder automation system was executed at three levels. Bench testing of the DA system was carried out using a DA Simulation program that was built using Visual Basic tools and integrated to an ACCESS database to represent the field installed system. The DA Simulator provided visual graphic feedback of the implemented DA process and logic is also verifiable through an extensive log file.

Field simulation testing is carried out in the field at the DA-Master equipment installed at the substation. Key data values are forced into the DA-Master processor using "batch" files to override real polled information obtained through normal communications methods. The simulations can be run test various first and second contingency fault conditions in the field. Simulated field tests are most valuable in testing and optimizing settings of the communications schemes used for DA.

Fault injection testing was executed to provide final and complete testing of the DA system. Fault injection testing

Contact:

NovaTech, LLC
15541 W 110th ST
Lenexa, KS 66219

T: 913.451.1880
F: 913.451.2845
www.novatechweb.com

does not utilize simulated field conditions and thus provides a necessary and practical means to testing the real-time interactions between protective IEDs, telecommunications equipment, substation RTU and distribution automation control system.

BIOGRAPHY

Russell Fanning is a Principal Engineer at We-Energies in Milwaukee, WI, working in the Research & Development group to develop Distribution Automation Systems. Russ has over 27 years experience working in Distribution Protection, Substation Engineering, Geofacilities Information Systems Development and Distribution Planning Support. He received a B.S. in Electrical Engineering and Computer Science from Marquette University, is a member of IEEE and is a registered Professional Engineer in the State of Wisconsin.

Eric C. Schultz has a B.S. in Electrical Engineering from the University of Oklahoma and has more than twelve years of experience in the electric utility industry, including consulting and turnkey project experience in power plant and substation design, control and protection design, and construction. For the last nine years, Mr. Schultz has worked exclusively in the areas of SCADA, substation automation, and distribution automation design and implementation, completing well over 75 projects for numerous utility and industrial customers in that period and assisting in product development for a number of communications-related products aimed at the electric utility industry. Mr. Schultz is currently the Technical Sales Manager for NovaTech, LLC in Lenexa, Kansas, employed there since 1996, and is a registered Professional Engineer in the State of Kansas.

Patrick Russo is Software Manager at NovaTech, LLC in Lenexa Kansas. Pat oversees integration of SCADA & IED protocols into the Orion Automation Platform, working closely with NovaTech's substation and distribution automation project engineers. He has 16 years of SCADA and communications experience, specializing in integration of customer specified equipment. Pat has a B.S. degree in Electronic Engineering from the University of Dayton, Ohio.

REFERENCES

[1] Distribution Automation Applications Made Simple: Modeling, Evaluating and Implementing DA Using the "POD" method, by Russell Fanning, P.E., Wisconsin Electric, presented at Distributech 2002 in Miami Beach, FL

[2] "Premium Operating Districts" provide Superior Reliability for Industrial Customers using the DV2010 Primary Voltage Network, by Russell Fanning, P.E. for DistribuTECH 2004, Orlando, FL



Putting Your DA To The Test

Contact:

NovaTech, LLC
15541 W 110th ST
Lenexa, KS 66219

T: 913.451.1880
F: 913.451.2845
www.novatechweb.com